

PURCHASER	P.O. #	DATE
PROJECT	LOCATION	
ENGINEER	ARCHITECT	
SUBMITTED BY	FOR APPROVAL	FOR REFERENCE

ITEM	PLAN DESIGNATION	QUANTITY	COOLING BTU/H	VOLTAGE	FRIEDRICH MODEL

Features

- 230/208 Single Zone Heat Pump
- Precision Inverter® technology (variable speed compressor)
- Soft start compressor
- BLDC motor
- High efficiency for low operating cost
- DiamonBlue Advanced Corrosion Protection®
- Auto Clean indoor coil
- Cooling/Heating/Fan/Auto mode
- Surge Cool/Heat
- Natural air flow
- Ultra quiet operation
- Sleep mode
- Auto restart
- Auto changeover
- 24-hour on/off timer
- ENERGY STAR® qualified model
- Hidden display (only visible during operation)



FRHSW09A3B, FRHSW12A3B

Built-in Wi-Fi for control anytime, anywhere

- Easy to use FriedrichGo™ app
- Create customizable, 7-day schedules
- Control with smartphone
- Compatible with Amazon Alexa and Google Home



WIRELESS
 REMOTE CONTROL

OPERATION IN EXTREME CONDITIONS

- Low ambient operation down to 0° F (Cooling mode)
- Low ambient operation down to -13° F (Heating mode)
- Low temperature compressor start-up protection



FRHSR09A3A, FRHSR12A3A



SPECIFICATIONS

PERFORMANCE RATINGS		Single Zone - Wall-Mounted - Heat Pumps	
SYSTEM MODEL NO.		FRHW093A	FRHW123A
INDOOR MODELS		FRHSW09A3B	FRHSW12A3B
OUTDOOR MODEL		FRHSR09A3A	FRHSR12A3A
SPECIFICATIONS			
CAPACITY COOLING (RATED)	Btu	9000	12000
CAPACITY COOLING (MIN-MAX)	Btu	3600-10000	4000-13500
CAPACITY HEATING @47°F (RATED)	Btu	10500	13000
CAPACITY HEATING @17°F (RATED)	Btu	6500	8000
CAPACITY HEATING (MIN-MAX)	Btu	3600-10500	4000-14000
SENSIBLE HEAT RATIO		76%	77%
HSPF/HSPF2		12.5/10.0	12.0/10.5
SEER/SEER2		28.0/27.5	25.0/24.5
EER		16.1	15.4
ENERGY STAR		YES	YES
MOISTURE REMOVAL	Pts/h	1.9	2.5
AIRFLOW (QUIET, LOW, MED, HIGH)	CFM	416/384/355/279	598/536/446/345
SOUND RATING - INDOOR	dB-A	39/34/31	45/41/39
SOUND RATING - OUTDOOR	dB-A	55	55
OPERATING RANGE (COOLING)	°F	0°-115°	0°-115°
OPERATING RANGE (HEATING)	°F	-13°-75°	-13°-75°
EST. YEARLY OPERATING COST	\$	50	70
ELECTRICAL DATA			
POWER SOURCE	V-Hz-Phase	230/208-60-1	230/208-60-1
MINIMUM AMPACITY	A	10A	12A
COOLING WATTS	W	559	779
COOLING AMPS		2.3	4.6
HEATING WATTS	W	905	856
HEATING AMPS		3.4	4.8
MAX. TD FUSE/BREAKER	A	15A	15A
POWER AND COMMUNICATION CABLE	No. x AWG	4 x 14AWG	4 x 14AWG
REFRIGERATION SYSTEM			
REFRIGERANT		R410a	R410a
COMPRESSOR TYPE		Rotary	Rotary
CONNECTIONS		Flare	Flare
LIQUID LINE O.D.	in	1/4	1/4
SUCTION LINE O.D.	in	3/8	3/8
FACTORY PRECHARGE	ft	25	25
REFRIGERANT CHARGE	oz	38.8	45.9
MIN./MAX. LINE LENGTH	ft	10-66	10-66
MAX. HEIGHT DIFFERENCE	ft	33	33
DIMENSIONS & WEIGHT			
INDOOR UNIT			
W X H X D	in	33 7/8 x 11 1/8 x 8 1/2	38 1/8 x 13 1/8 x 10
NET WEIGHT	lbs	22	28.5
SHIPPING WEIGHT	lbs	26.5	34
OUTDOOR UNIT			
W X H X D	in	31 7/8 x 23 x 11	31 7/8 x 23 x 11
NET WEIGHT	lbs	75	84
SHIPPING WEIGHT	lbs	81.5	92.5
TOTAL NET WEIGHT	lbs	97	112.5
TOTAL SHIPPING WEIGHT	lbs	108	126.5

Your energy costs will depend on your utility rates and use. The estimated energy cost is based on a electricity cost of \$.13 per kWh. For more information, visit www.ftc.gov/energy. Due to continuing research in new energy-saving technology, specifications are subject to change without notice.



DIMENSIONAL DRAWINGS
INDOOR UNIT / FRHSW09A3B

	W	H	D
FRHSW09A3B	33 7/8"	11 3/16"	8 1/2"

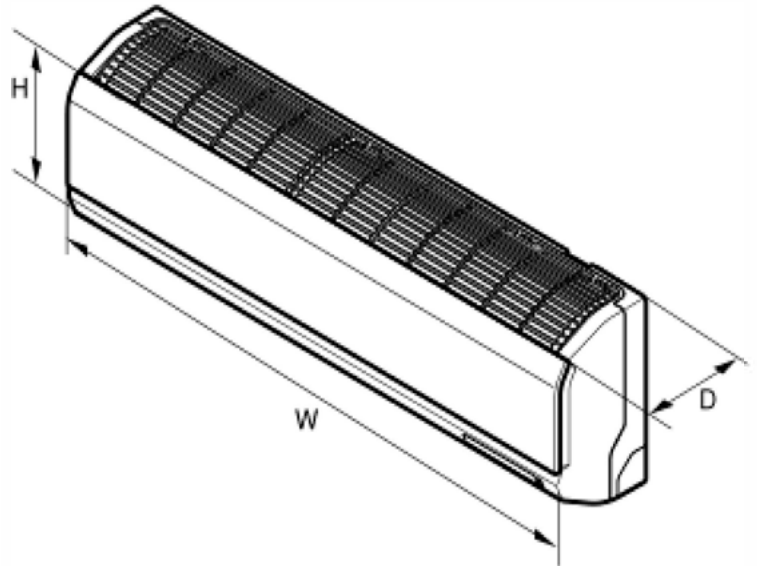

INDOOR UNIT / FRHSW12A3B

	W	H	D
FRHSW12A3B	38 1/8"	13 1/8"	9 15/16"

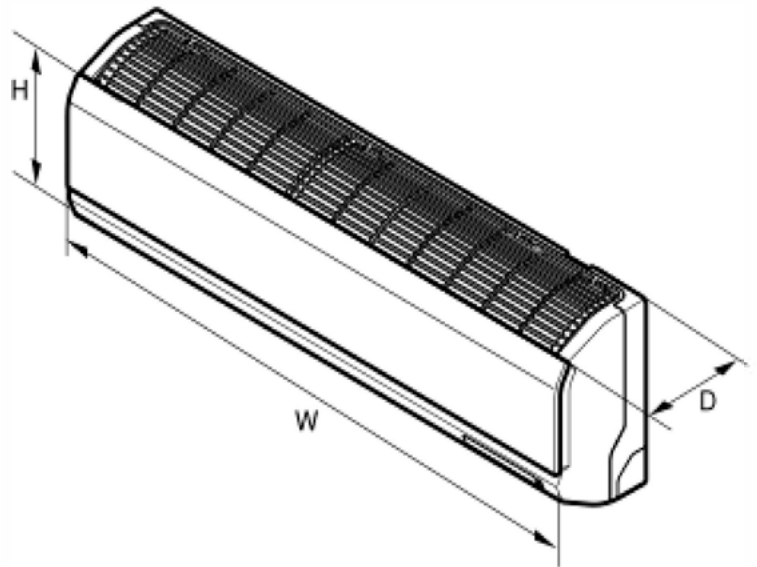

DIMENSIONAL DRAWINGS

OUTDOOR UNITS / FRHSR09A3A, FRSHR12A3A

Outdoor units:

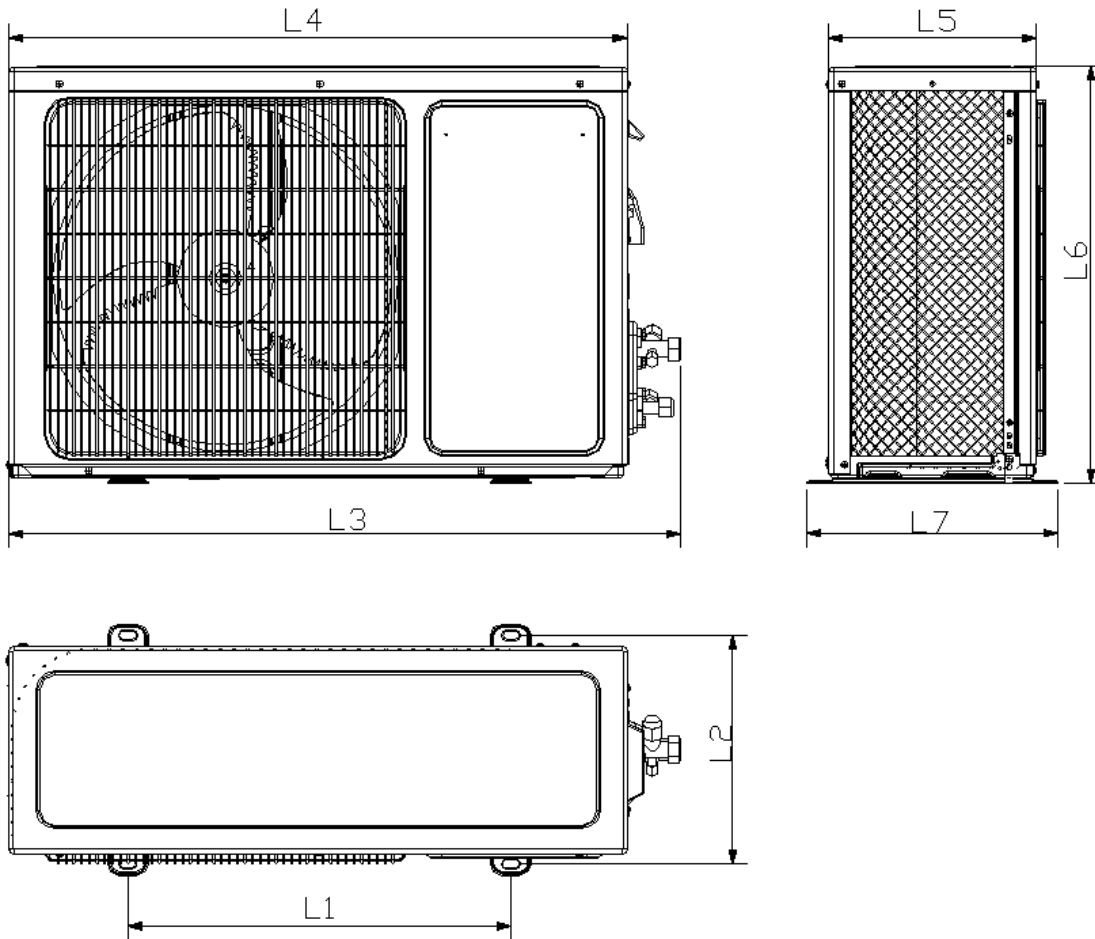

				Width	Depth	Height	
Model	L1 (in.)	L2 (in.)	L3 (in.)	L4 (in.)	L5 (in.)	L6 (in.)	L7 (in.)
FRHSR09A3A	20 1/16	12 19/32	34 7/8	31 7/8	11	23	13
FRHSR12A3A							

ACCESSORIES

REFRIGERATION LINE SETS* (Required accessory)

Kit#	Length (ft.)	Liquid	Suction	System Model
T32350	35'	1/4"	3/8"	FRHW093
				FRHW123

*Insulated line sets are available for all Friedrich split systems in 15 ft. and 35 ft. lengths. Each line set is equipped with flare nuts on both ends. Both liquid and suction lines are insulated. Line sets can be joined together with field supplied double male connectors. Each system requires one line set for each indoor unit installed.

REFRIGERATION LINE SETS MIN./MAX. LENGTHS

Floating Air® Premier		
System Model	Min. (ft.)	Max. (ft.)
FRHW093	10	66
FRHW123	10	66

TORQUE WRENCH SETTINGS

Outside Diameter		Torque	
mm	inch	ft-lbs.	N-m
6.35	1/4	13 – 18	17.6 – 24.5
9.52	3/8	25 – 30	33.3 – 41.2
12.7	1/2	40 – 47	53.9 – 64.7
15.88	5/8	45 – 59	61.7 – 80.4

WALL CONTROLLERS (OPTIONAL)



FPWC1
Optional wired wall controller for Floating Air® Premier models.

FreshAir® IAQ READY

Introducing Friedrich FreshAir® IAQ.

Proven solutions that improve the health and quality of indoor air, and ease customer concerns about the air they breathe. Easy-to-install FreshAir IAQ accessories improve the health and quality of indoor air.

AIR PURIFICATION

FreshAir® Purifier APWM1

FreshAir Purifier by iWave® features needlepoint bi-polar ionization to address any mold, bacteria, virus, allergens, and VOC's that may be in your air stream to ensure delivery of healthy, clean, purified air. Optional accessory for all Friedrich wall-mounted ductless models.



ULTRAVIOLET LED

Friedrich UV UVL1

Germicidal UV light kits have been tested and certified for use on Friedrich products. The UV kit can be installed on the indoor coil and is designed to disinfect surfaces and the air as it circulates through the ventilation system. UV light can kill airborne bacteria, viruses, mold, reduce maintenance costs and extend the life of an HVAC system. Optional accessory for all Friedrich wall-mounted ductless models.

